

Ma-Rain 56



TUV 50 100 8910/4
CERTIFIED

MARANI IRRIGAZIONE SRL
Via Scaglia Est, 5 - 41126 Modena - ITALY
Tel. +39 059 702 304 - Fax +39 059 490 67 18
info@marani-italy.com - www.marani-italy.com



Ma-Rain 56



I GB D F E

marani-italy.com

01.11.2019 - www.tredigraph.com



Ma-Rain 56



Il case compatto comprendente:

- 1. Display 4" a colori con alto contrasto.
- 1.1. Encoder ottico per una rapida selezione delle funzioni.
- 1.2. 2 x 4 tasti con retroilluminazione per la navigazione.
- 1.3. Tasti aggiuntivi per gestione allarmi.
- 2. Modulo I/O di controllo.
- 3. Pulsante di Accensione/Spegnimento.

Compact case with:

- 1. 4" high contrast, colour display.
- 1.1. Optical encoder, for a fast selection of settings.
- 1.2. 2 x 4 keys for navigation with back lighting.
- 1.3. Additional keys for alarm setting.
- 2. I/O control module.
- 3. On/Off key.

Kompakter Case bestehend aus:

- 1. 4" Farbdisplay mit hohem Kontrast.
- 1.1. Optischer Encoder zur schnellen Funktionsauswahl.
- 1.2. 2 x 4 Tasten mit Hintergrundbeleuchtung für die Navigation.
- 1.3. Zusätzliche Tasten für die Alarmkontrolle.
- 2. I/O-Modul für Kontrolle.
- 3. Ein-Ausschalter.

Boite compacte comprenant:

- 1. Afficheur 4" couleur à contraste élevé.
- 1.1. Molette de sélection de fonction.
- 1.2. 2 x 4 touches avec rétro éclairage pour la navigation.
- 1.3. Touches supplémentaires pour gestion alarmes.
- 2. Module E/S de contrôle.
- 3. Touche de démarrage / arrêt.

Case compacto que comprende:

- 1. Pantalla a color de 4" con alto contraste.
- 1.1. Encoder óptico para una rápida selección de funciones.
- 1.2. 2 x 4 Teclas con luz de fondo para la navegación.
- 1.3. Teclas adicionales para la gestión de alarmas.
- 2. Módulo de control de I/O.
- 3. Botón de encendido / apagado.

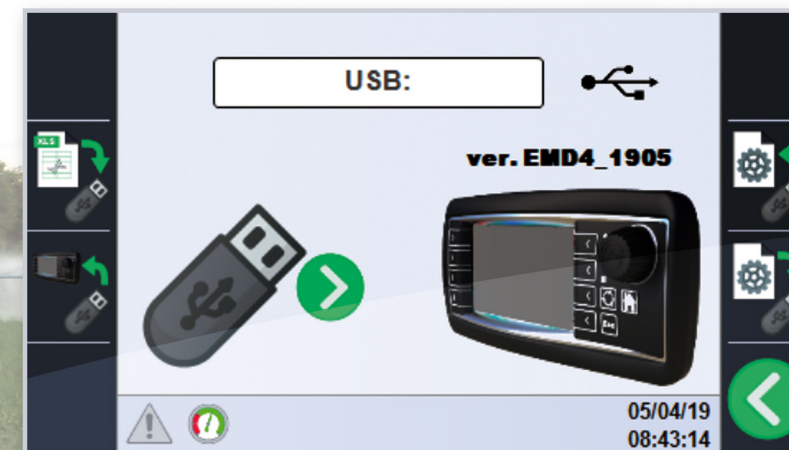
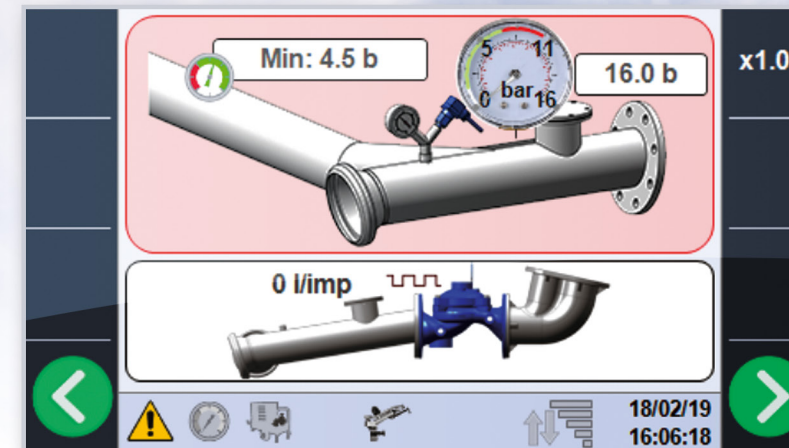
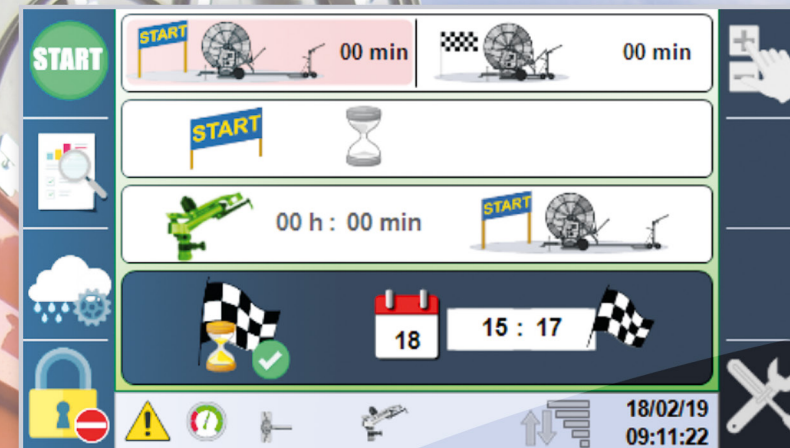

Comandi e funzionalità gestiti con grafica intuitiva che non necessita di testi in lingua.
Commands and features have an intuitive graphical user interface, to avoid keys in the lingo.
 Befehle und Funktionen werden mit intuitiven Grafiken verwaltet, ohne Sprachtexte.
Commandes et fonctionnalités gérées par graphiques intuitifs sans texte.
 Comandos y funciones gestionados con interfaz gráfica.



Elenco allarmi dettagliato con richiami espliciti alla componentistica.
Detailed alarm chart, with explicit reference to the components.
 Liste der detaillierten Alarme mit Verweisen auf die Komponenten.
Liste détaillée des alarmes avec référence aux composants.
 Lista de alarmas detalladas con referencia a los componentes.



Programmazione parametri /dati macchina intuitiva e veloce.
Fast and easy parameters/datas' settings.
 Intuitive und schnelle Maschinenparameter-/ Datenprogrammierung.
Programmation des paramètres / données machine intuitive et rapide.
 Programación intuitiva y rápida de parámetros / datos de la máquina.



Possibilità di aggiornare il software di controllo tramite chiavetta USB in loco.
Software's update with USB key.
 Möglichkeit zur Aktualisierung der Steuerungssoftware über USB-Stick.
Possibilité de mettre à jour le programme de contrôle avec clé USB.
 Posibilidad de actualizar el software de control a través de una memoria USB.